

Symbol	Qty	Label	Arrangement	Lumens
	4	CEL-B	BACK-BACK	107800
	4	CEL-A	SINGLE	107800

Label	CalcType	Units	Avg	Max	Min	Avg/Min	Max/Min
COURT 1	illumiance	lux	457.00	590	318	1.44	1.86
COURT 2	illumiance	lux	521.78	602	434	1.20	1.39
COURT 3	illumiance	lux	457.63	589	320	1.43	1.84

## POLE AND BRACKET SPECIFICATIONS

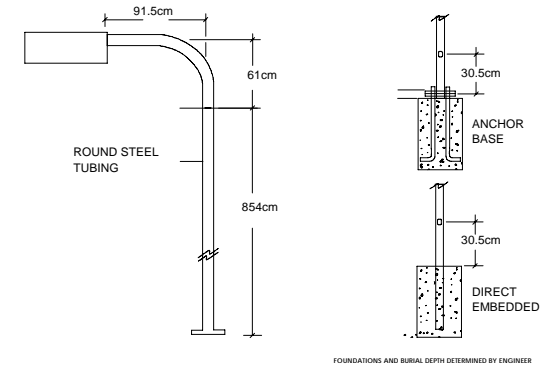

**NOTES:**  
 POLES SPACED 7.6M FROM NET LINE  
 POLES SHALL HAVE 6cm X 12cm HIGH STRENGTH TENON FOR MOUNTING

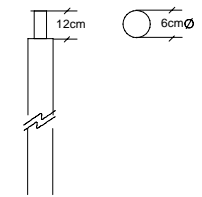

J&H Electric  
 Works Current Inc.  
 1001 Lakeshore Road East  
 Mississauga, Ontario  
 L4X 1R7  
 Tel: 905-271-9288  
 Fax: 905-271-9289  
 jandhelectric@gmail.com